

EUROTECH 50CM DUAL FUEL FREESTANDING COOKER

ED-GEFC50WH/SS

INSTRUCTION MANUAL

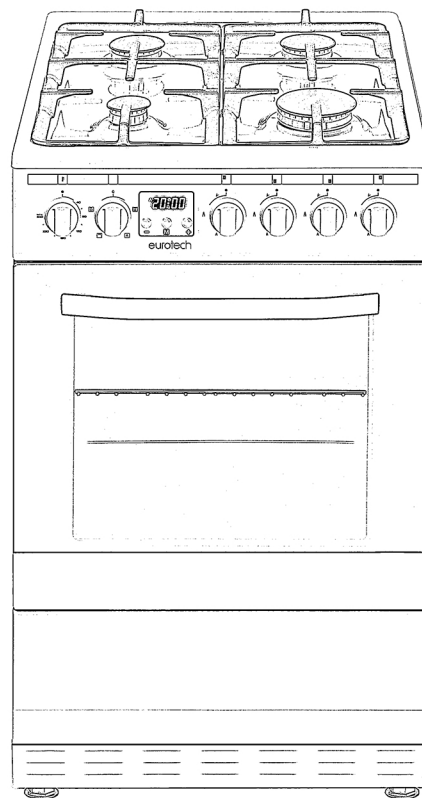

PLEASE READ THIS MANUAL CAREFULLY BEFORE
USING YOUR PRODUCT AND KEEP IT FOR FUTURE
REFERENCE.



Dear User,

Our objective is to make this product provide you with the best output which is manufactured in our modern facilities in a careful working environment, in compliance with total quality concept.

Therefore, we suggest you to read the user manual carefully before using the product and, keep it permanently at your disposal.

Note: This user manual is prepared for more than one model. Some of the features specified in the Manual may not be available in your appliance.

All our appliances are only for domestic use, not for commercial use.

Products marked with (*) are optional.

“Conforms with the WEEE Regulations.”

Contents

Important warnings.....	4
Methods for protecting ceramic glass cooking surface.....	13
Electrical connection.....	14
Introduction of the appliance.....	15
Accessories.....	16
Technical features of your oven.....	17
Installation of your oven.....	18
Chain lashing illustration.....	20
Control panel.....	20
Using oven section.....	21
Using the grill.....	22
Using the chicken roasting.....	22
Using cooker section.....	23
Program types.....	25
Cooking time table.....	26
Maintenance and cleaning.....	27
Installation of the oven door.....	28
Cleaning and maintenance of the Oven's front door glass.....	29
Changing the oven lamp.....	29
Catalytic walls.....	30
Rack positions.....	30
Using the grill deflector sheet.....	31
Troubleshooting.....	32
Handling rules.....	34
Recommendations for energy saving.....	34
Environmentally-friendly disposal.....	35
Package information.....	35

IMPORTANT WARNINGS

1. Installation and repair should always be performed by **“AUTHORIZED SERVICE”**. Manufacturer shall not be held responsible for operations performed by unauthorized persons.
2. Please read this operating instructions carefully. Only by this way you can use the appliance safely and in a correct manner.
3. The oven should be used according to operating instructions.
4. Keep children below the age of 8 and pets away when operating.
5. **WARNING: The accessible parts may be hot while using the grill. Keep away from children.**
6. **WARNING: Fire hazard; do not store the materials on the cooking surface.**
7. **WARNING: The appliance and its accessible parts are hot during operation.**
8. Setting conditions of this device are specified on the label. (Or on the data plate)
9. The accessible parts may be hot when the grill is used. Small children should be kept away.
10. **WARNING: This appliance is intended for cooking. It should not be used for other purposes like heating a room.**
11. To clean the appliance, do not use steam cleaners.

12. Ensure that the oven door is completely closed after putting food inside the oven.

13. NEVER try to put out the fire with water. Only shut down the device circuit and then cover the flame with a cover or a fire blanket.

14. Children under 8 years of age should be kept away, if they cannot be monitored continuously.

15. Touching the heating elements should be avoided.

16. CAUTION: Cooking process shall be supervised. Cooking process shall always be supervised.

17. This device can be used by children over 8 years of age, people with physical, hearing or mental challenges or people with lack of experience or knowledge; as long as control is ensured or information is provided regarding the dangers.

18. This device has been designed for household use only.

19. Children must not play with the appliance. Cleaning or user maintenance of the appliance shall not be performed by children unless they are older than 8 years and supervised by adults.

20. Keep the appliance and its power cord away from children less than 8 years old.

21. Put curtains, tulle, paper or any flammable (ignitable) material away from the appliance before starting to use the appliance. Do not put ignitable or flammable materials on or in the appliance.

- 22.** Keep the ventilation channels open.
- 23.** The appliance is not suitable for use with an external timer or a separate remote control system.
- 24.** Do not heat closed cans and glass jars. The pressure may lead jars to explode.
- 25.** Oven handle is not a towel drier. Do not hang towels, etc. on the oven handle.
- 26.** Do not place the oven trays, plates or aluminium foils directly on the oven base. The accumulated heat may damage the base of the oven.
- 27.** While placing food to or removing food from the oven, etc., always use heat resistant oven gloves.
- 28.** Do not use the product in states like medicated and/or under influence of alcohol which may affect your ability of judgement.
- 29.** Be careful when using alcohol in your foods. Alcohol will evaporate at high temperatures and may catch fire to cause a fire if it comes in contact with hot surfaces.
- 30.** After each use, check if the unit is turned off.
- 31.** If the appliance is faulty or has a visible damage, do not operate the appliance.
- 32.** Do not use the appliance with its front door glass removed or broken.
- 33.** Place the baking paper together with the food into a pre-heated oven by putting it inside a cooker or on an oven accessory (tray, wire grill etc.).

34. Do not put objects that children may reach on the appliance.

35. It is important to place the wire grill and tray properly on the wire racks and/or correctly place the tray on the rack. Place the grill or tray between two rails and make sure it is balanced before putting food on it.

36. Against the risk of touching the oven heater elements, remove excess parts of the baking paper that hang over from the accessory or container.

37. Never use it at higher oven temperatures than the maximum usage temperature indicated on your baking paper. Do not place the baking paper on the base of the oven.

38. When the door is open, do not place any heavy object on the door or allow children to sit on it. You may cause the oven to overturn or the door hinges to be damaged.

39. The packaging materials are dangerous for children. Keep packaging materials away from the reach of children.

40. Do not use abrasive cleaners or sharp metal scrapers to clean the glass as the scratches that may occur on the surface of the door glass may cause the glass to break.

41. Do not hit glass surfaces of vitro-ceramic cookers with a hard metal, resistance can get damaged. It may cause an electric shock.

- 42.** User should not handle the oven by himself.
- 43.** Food can spill when foot of oven is dismantled or gets broken, be careful. It may cause personal injuries.
- 44.** During usage, the internal and external surfaces of the oven get hot. As you open the oven door, step back to avoid the hot vapour coming out from the interior. There is risk of burning.
- 45.** Upper cover of the oven can be closed for a reason, than cookware can trip over. Step back to avoid the hot food coming on you. There is risk of burning.
- 46.** Do not place heavy objects when oven door is open, risk of toppling.
- 47.** User should not dislocate the resistance during cleaning. It may cause an electric shock.
- 48.** Do not place metal utensils such as knife, fork, spoon on the surface of the appliance, since they will get hot.
- 49.** Do not remove ignition switches from the appliance. Otherwise, live electric cables can be accessed. It may cause an electric shock.
- 50.** Oven supply can be disconnected during any construction work at home. After completing the work, re-connecting the oven shall be done by authorized service.
- 51.** Do not place metal utensils such as knife, fork, spoon on the surface of the appliance, since they will get hot.



52To prevent overheating, the appliance should not be installed behind of a decorative cover.

53. Turn off the appliance before removing the safeguards. After cleaning, install the safeguards according to instructions.

54. Cable fixing point shall be protected.

55. Please don't cook the food directly on the tray / grid. Please put the food into or on appropriate tools before putting them in the oven.

56. CAUTION: If the glass of the stove is broken, turn off any heating element immediately and disconnect the appliance from power source, do not touch the surface of the appliance and do not use the appliance.



Electrical Safety

1. Have an authorized electrician set grounding equipment. Our company shall not be responsible for the damages that shall be incurred due to using the product without grounding according to local regulations.

2. The circuit breaker switches of the oven shall be placed so that end user can reach them when the oven is installed.

3. The power supply cord shall not contact the hot parts of the appliance.

4. If the power supply cord is damaged, this cord shall be replaced by the manufacturer or its service agent or an equally qualified personnel to prevent a hazardous situation.

5. Never wash the product by spraying or pouring water on it! There is a risk of electrocution.

6. WARNING: To avoid electric shock, ensure that the device circuit is open before changing the lamp.

7. WARNING: Cut off all supply circuit connections before accessing the terminals.

8. WARNING: If the surface is cracked, turn off the appliance to avoid risk of electric shock.

9. Do not use cut or damaged cords or extension cords other than the original cord.



10. The rear surface of the oven also heats up when the oven is operated. Electrical connections shall not touch the rear surface, otherwise the connections may be damaged.

11. Do not tighten the connecting cables to the oven door and do not run them over hot surfaces. If the cord melts, this may cause the oven to short circuit and even a fire.

12. If the power supply cable is damaged, it must be replaced by its manufacturer or authorized technical service or any other personnel qualified at the same level, in order to avoid any dangerous situation.

13. Do not use steam cleaners for cleaning the appliance, otherwise electric shock may occur.

14. An omnipolar switch capable to disconnect power supply is required for installation. Disconnection from power supply shall be provided with a switch or an integrated fuse installed on fixed power supply according to building code.

15. Appliance is equipped with a **type “Y”** cord cable.

16. Fixed connections shall be connected to a power supply enabling omnipolar disconnection. For appliances with over voltage category below III, disconnection device shall be connected to fixed power supply according to wiring code.



Intended Use

- 1.** This product has been designed for domestic use. Commercial use is not permitted.
- 2.** This appliance may only be used for cooking purposes. It shall not be used for other purposes like heating a room.
- 3.** This appliance shall not be used to heat plates under the grill, drying clothes or towels by hanging them on the handle or for heating purposes.
- 4.** The manufacturer assumes no responsibility for any damage due to misuse or mishandling.
- 5.** Oven part of the unit may be used for thawing, roasting, frying and grilling food.
- 6.** Operational life of the product you have purchased is 10 years. This is the period for which the spare parts required for the operation of this product as defined is provided by the manufacturer.

Methods for Protecting Ceramic Glass Cooking Surface

Ceramic glass surface is unbreakable and scratch resistant to a certain degree. However, to avoid any damage, please do the following:

1. Never pour cold water on hot cookers.
2. Do not stand on a ceramic glass plate.
3. Sudden pressure, for example, the effect of a falling salt shaker may be critical. So, do not place such objects on a place above the hobs.
4. After each use, make sure that the base of the cooking pot and surfaces of cooking zones are clean and dry.
5. Do not peel vegetables on the hob surfaces. Sand grains falling from the vegetables may scratch the ceramic glass plate.
6. Do not lay flammable materials such as cardboard or plastic on the oven. Objects such as tin, zinc, or aluminium (as well as aluminium foils or empty coffee pots) may melt on hot cooking surfaces and thus cause damage.
7. Take care not to let sugary foods or fruit juices contact the hot cooking zones. The ceramic glass surface may be stained by these.

Electrical Connection

1. Your oven requires 40 Amp fuse for mono phase or 3x16 Amp fuse for 3 phase supply according to electrical power for cooker section has 4 ceramic heater and oven section has electric models. Installation by a qualified electrician is mandatory.

2. Your oven is adjusted in compliance with 220-240V / 380-415V AC,50/60Hz. electric supply. If the mains are different from this specified value, contact your authorized service.

3. Electrical connection of the oven should only be made to connections / sockets with an earth system installed in compliance with local regulations. If there are no connections/sockets with an earth system in place where the oven will be installed, immediately contact a qualified electrician to install. The manufacturer is not responsible for damages that will arise because of the appliance not be connected to an earth system.

4. If your supply cable gets damaged, it should be replaced by an authorized service agent or qualified electrician in order to avoid danger or electric shock.

5. Electrical cable should not touch the hot parts of the appliance.

6. Operate your oven in dry atmosphere.

7. When placing your oven to its location, ensure that it is at the counter level. Bring it to the counter level by adjusting the feet if necessary.

Electrical Connection Scheme

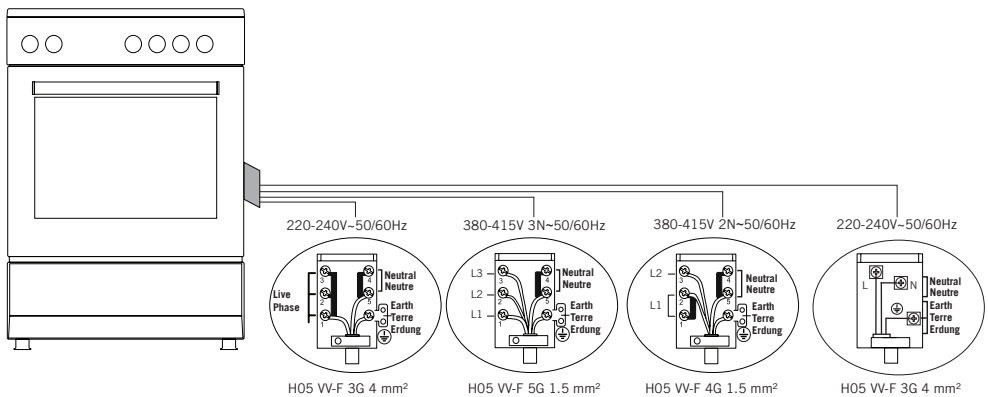

INTRODUCTION OF THE APPLIANCE

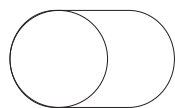

11

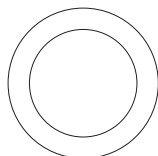

12

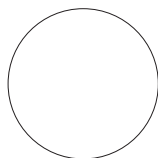

13

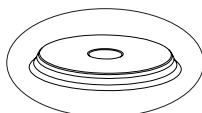

14

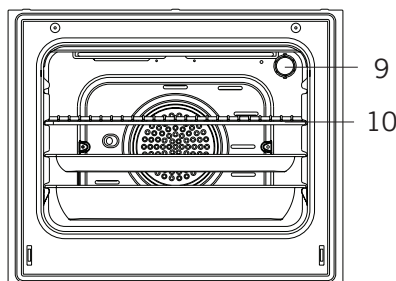
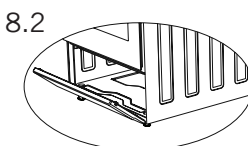
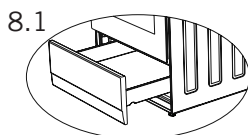
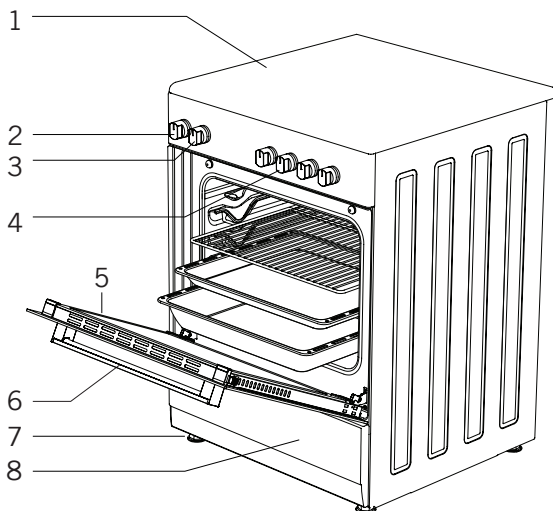

- 1. Glass top plate
- 2. Thermostat knob
- 3. Command knob for oven
- 4. Regulators for vitroceramic hobs
- 5. Oven door
- 6. Handle
- 7. Plastic leg
- 8. Lower cabinet door

- 8.1. Drawer
- 8.2. Flap door
- 9. Lamp
- 10. Grill
- 11. Ceramic heater (140 mm / 250 mm)
- 12. Ceramic heater (120 mm / 180 mm)
- 13. Ceramic heater (140 mm or 180 mm)
- 14. Hot plate (145 mm or 185 mm)

Accessories

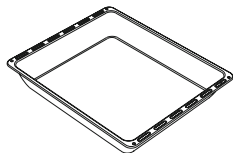

Deep tray *

Used for pastry, big roasts, watery foods. It can also be used as oil collecting container if you roast directly on grill with cake, frozen foods and meat dishes.



Tray / Glass tray *

Used for pastry (cookie, biscuit etc.), frozen foods.

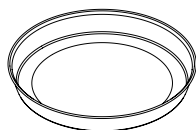

Circular tray *

Used for pastry frozen foods.

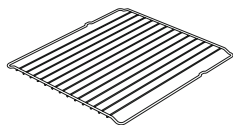

Wire grill

Used for roasting or placing foods to be baked, roasted and frozen into desired rack.

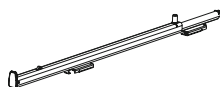

Telescopic rail *

Trays and wire racks can be removed and installed easily thanks to telescopic rails.

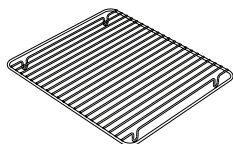

In tray wire grill *

Foods to stick while cooking such as steak are placed on in tray grill. Thus contact of food with tray and sticking are prevented.

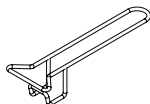

Tray handle *

It is used to hold hot trays.

Technical features of your oven

Specifications	50x55	50x60	60x60
Outer width	500 mm	500 mm	600 mm
Outer depth	565 mm	630 mm	630 mm
Outer height	855 mm	855 mm	855 mm
Lamp power	15-25 W		
Bottom heating element	1000 W	1000 W	1200 W
Top heating element	800 W	800 W	1000 W
Turbo heating element	-----	1800 W	2200 W
Grill heating element	1500 W	1500 W	2000 W
Supply voltage	220-240V AC/380-415V AC 50/60 Hz		
Hot plate 145 mm *	1000 W		
Hot plate 180 mm *	1500 W		
Hot plate rapid 145 mm *	1500 W		
Hot plate rapid 180 mm *	2000 W		
Ceramic heater 140 mm *	1200 W		
Ceramic heater 180 mm *	1700 W / 1800 W		
Ceramic heater 140 mm / 250 mm *	1800 W		
Ceramic heater 120 mm / 180 mm *	1700 W		

WARNING: For the modification to be done by authorized service, this table should be considered. Manufacturer may not be held responsible for any problems rising because of any faulty modification.

WARNING: In order to increase the product quality, the technical specifications may be changed without prior notice.

WARNING: The values provided with the appliance or its accompanying documents are laboratory readings in accordance with the respective standards. These values may differ depending on the use and ambient conditions.



INSTALLATION OF YOUR OVEN

Check if the electrical installation is proper to bring the appliance in operating condition. If electricity installation is not suitable, call an electrician and plumber to arrange the utilities as necessary. Manufacturer shall not be held responsible for damages caused by operations performed by unauthorized persons.

WARNING: It is customer's responsibility to prepare the location the product shall be placed on and also to have the electrical installation prepared.

WARNING: The rules in local standards about electrical installations shall be followed during product installation.

WARNING: Check for any damage on the appliance before installing it. Do not have the product installed if it is damaged. Damaged products cause a risk for your safety.

Right Place for Installation and Important Warnings

Appliance feet should not stay on soft surfaces such as carpets. The kitchen floor shall be durable to carry the unit weight and any other kitchenware that may be used on the oven.

Appliance should be used with a clearance of minimum 400 mm over the upper hob surfaces, and 65 mm from side surfaces inside a kitchen furniture.

The appliance is suitable for use on both side walls, without any support, or without being installed in a cabinet. If a hood or aspirator will be installed above the cooker, follow the instructions of the manufacturer for height of mounting. (min. 650 mm)

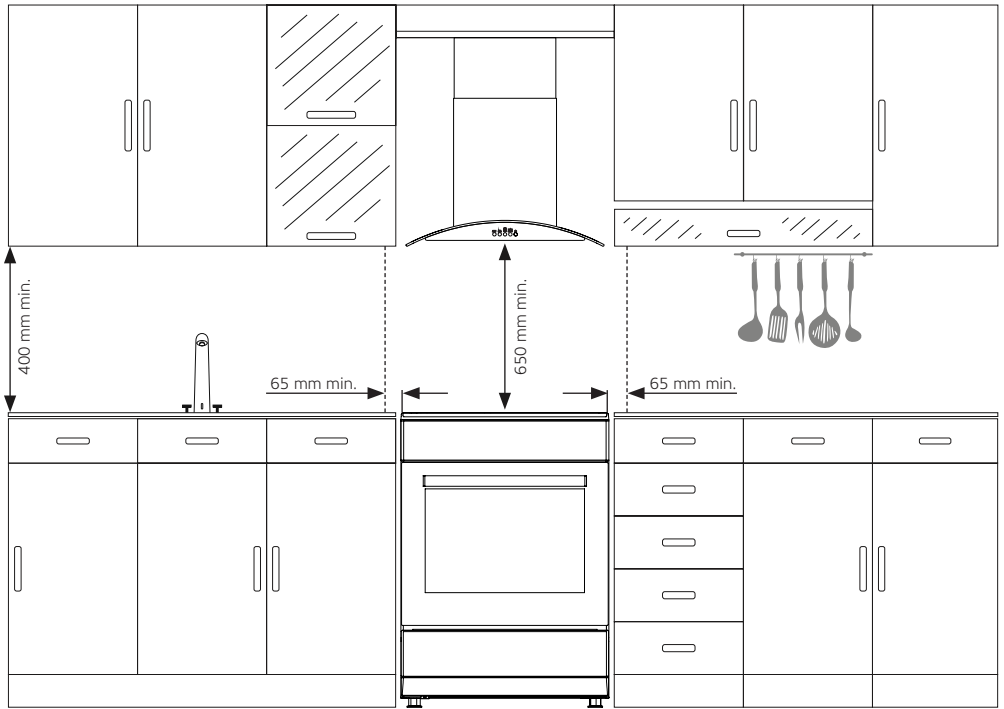

WARNING: The kitchen furniture near the appliance must be heat resistant.

WARNING: Do not install the appliance beside refrigerators or coolers. Heat radiated by the appliance increases the energy consumption of cooling devices.

WARNING: Do not use the door and/or handle to carry or move the appliance.

Chain lashing illustration

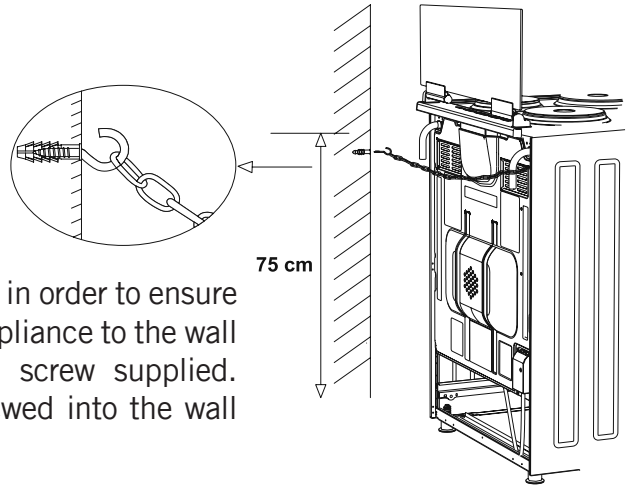

Before using the appliance, in order to ensure safe use, be sure to fix the appliance to the wall using the chain and hooked screw supplied. Ensure that the hook is screwed into the wall securely.

CONTROL PANEL

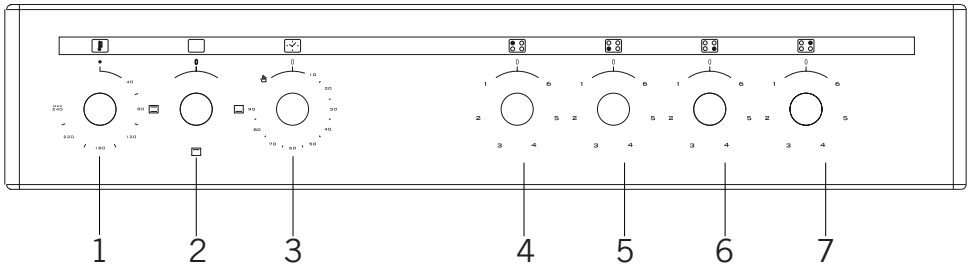

1. Thermostat
2. Function selection button
3. Mechanical timer *
4. Rear left electrical heater
5. Front left electrical heater
6. Front right electrical heater
7. Rear right electrical heater

WARNING: The control panel above is only for illustration purposes. Consider the control panel on your device.

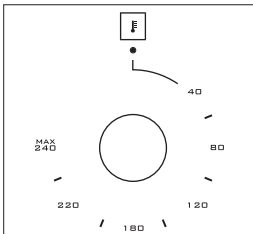

Thermostat: Used for determining the cooking temperature of the dish to be cooked in the oven. After placing the food inside the oven, turn the switch to adjust desired temperature setting between 40-240 °C. For cooking temperatures of different food, see cooking table.

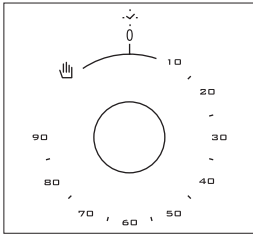

Mechanical timer*: Used for determining the period for cooking in the oven. When adjusted time is expired, power to heaters is turned off and an audible warnig signal is emitted. Mechanical timer can be adjusted to desired period between 0-90 minutes. For cooking periods, see cooking tables.

USING OVEN SECTION

Using Oven Heating Elements

1. When your oven is operated first time, an odor will be spread out which will be sourced from using the heating elements. In order to get rid of this, operate it at 240 °C for 45-60 minutes while it is empty.
2. Oven control knob should be positioned to desired value; otherwise oven does not operate.
3. Kinds of meals, cooking times and thermostat positions are given in cooking table. The values given in the cooking table are characteristic values and were obtained as a result of the tests performed in our laboratory. You can find different flavors suitable for your taste depending on your cooking and using habits.
4. You can make chicken revolving in your oven by means of the accessories.
5. Cooking times: The results may change according to the area voltage and material having different quality, amount and temperatures.
6. During the time when cooking is being performed in the oven, the lid of the oven should not be opened frequently. Otherwise circulation of the heat may be imbalanced and the results may change.

Using The Grill

1. When you place the grill on the top rack, the food on the grill shall not touch the grill.
2. You can preheat for 5 minutes while grilling. If necessary, you may turn the food upside down.
3. Food shall be in the center of the grill to provide maximum air flow through the oven.

To turn on the grill;

1. Place the function button over the grill symbol.
2. Then, set it to the desired grill temperature.

To turn the grill off;

Set the function button to the off position.

WARNING: Keep the oven door closed while grilling.

Using The Chicken Roasting *

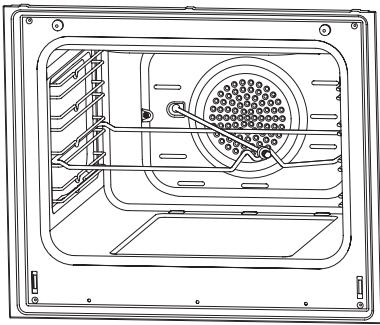

Figure 1

Place the spit on the frame. Slide turn spit frame into the oven at the desired level. Locate a dripping pan through the bottom in order to collect the fat. Add some water in dripping pan for easy cleaning. Do not forget to remove plastic part from spit. After grilling, screw the plastic handle to the skewer and take out the food from oven.

Using Cooker Section

Using And Description Of Hob Section For Vitroceramic

	Level 1	Level 2	Level 3	Level 4	Level 5	Level 6	Level 7	Level 8	Level 9	Max.
140 mm Commutator	130 W	206 W	350 W	500 W	850 W	1200 W	---	---	---	---
180 mm Commutator	180 W	470 W	790 W	850 W	1230 W	1700 W	---	---	---	---
180 mm Regulator	1800 W	1800 W	1800 W	1800 W	1800 W	1800 W	1800 W	1800 W	1800 W	---
140/250 mm	1000 W	1000 W	1000 W	1000 W	1000 W	1000 W	1000 W	1000 W	1000 W	1800 W
120/180 mm Dual Hilight	700 W	700 W	700 W	700 W	700 W	700 W	700 W	700 W	700 W	1700 W

1. You operate the hob with the ring switches on the control panel of oven. This switch regulates the energy in order to reach desired temperature set by you.

2. In order to have a good cooking result from the hob, the pans bottom should be as thick and flat as possible.

3. Bottom of pans and cooking zones should be the same size. If possible, always place lids on the pans. Always place cookware on the cooking zone before it is switched on. Switch cooking zones off before the end of the cooking time, to take advantage of residual heat.

4. Turn the knob to clockwise for starting to operate. Temperature set up by the knob position on the line gradually increasing up to max. (Single zone)

5. For dual cooking zone the first ring operating like single zone; second ring starts to operate after extra turning by some more force to clock wise on the "max" region end of the ring sign. When you turn to counter clock wise, the first ring will operate as maximum range and the second ring's power will reduce up to you desire temperature.

Using Hot Plates

	Level 1	Level 2	Level 3	Level 4	Level 5	Level 6
80 mm	200 W	250 W	450 W	---	---	---
145 mm	250 W	750 W	1000 W	---	---	---
180 mm	500 W	750 W	1500 W	---	---	---
145 mm rapid	500 W	1000 W	1500 W	---	---	---
180 mm rapid	850 W	1150 W	2000 W	---	---	---
145 mm	95 W	155 W	250 W	400 W	750 W	1000 W
180 mm	115 W	175 W	250 W	600 W	850 W	1500 W
145 mm rapid	135 W	165 W	250 W	500 W	750 W	1500 W
180 mm rapid	175 W	220 W	300 W	850 W	1150 W	2000 W
220 mm	220 W	350 W	560 W	910 W	1460 W	2000 W

1. Electric hotplates have standard of 6 temperature levels. (as describe herein above)

2. When using first time, operate your electric hotplate in position 6 for 5 minutes. This will make the agent on your hotplate which is sensitive to heat get hardened by burning.

3. Use flat bottomed saucepans which fully contact with the heat as much as you can, so that you can use the energy more productively.

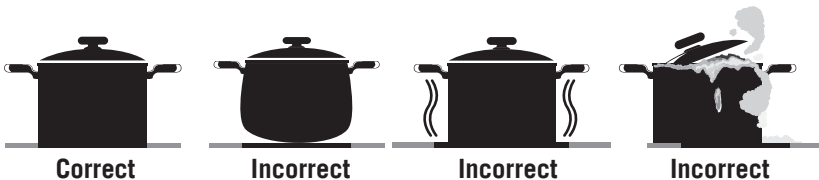

PROGRAM TYPES

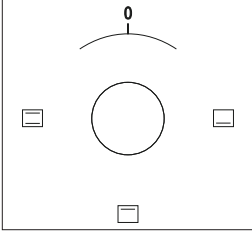

Function Button: Used for determining the heaters to be used for cooking the dish to be cooked in the oven. Heater program types in this button and their functions are described below. All heater types and program types consisting of these heaters may not be available at all models.

	Turnspit		Fan
	Top + Bottom heating element		Turbo heating + Fan
	Lamp		Bottom + Top heating elements + Fan
	Bottom heating element + Fan		Grill heating element + Fan
	Grill heating element		Grill burner / Grill heating element
	Grill heating element + Lamp		Top heating element
	Electrical timer		Oven burner / Bottom heating element

WARNING: All heater types and program types consisting of these heaters may not be available at all models.

COOKING TIME TABLE

WARNING: Oven must be preheated for 10 minutes before placing the food in it.

Foods	Cooking Function	Temperature (°C)	Rack Position	Cooking Duration (min.)
Cake (Tray / Mold)	Static / Static+fan	170-180	2	35-45
Small cakes	Static / Turbo+fan	170-180	2	25-30
Patty	Static / Static+fan	180-200	2	35-45
Pastry	Static	180-190	2	25-30
Cookie	Static	170-180	3	20-25
Apple pie	Static / Turbo+fan	180-190	2	50-70
Sponge cake	Static	200/150 *	2	20-25
Pizza	Static+fan	180-200	3	20-30
Lasagna	Static	180-200	2	25-40
Meringue	Static	100	2	60
Chicken	Static+fan / Turbo+fan	180-190	2	45-50
Grilled chicken **	Grill	200-220	4	25-30
Grilled fish **	Grill+fan	200-220	4	25-30
Sirloin steak **	Grill+fan	Max.	4	15-20
Grilled meat balls **	Grill	Max.	4	20-25

* Without pre-heating. Half of the cooking should be 200 °C and then second half should be 150 °C.

** During the half of cooking, meal should be turned around.

MAINTENANCE AND CLEANING

1. While oven is operating or shortly after it starts operating, it is extremely hot. You must avoid touching from heating elements.
2. Never clean the interior part, panel, lid, trays and all other parts of the oven by the tools like hard brush, cleaning mesh or knife. Do not use abrasive, scratching agents and detergents.
3. After cleaning the interior parts of the oven with a soapy cloth, rinse it and then dry thoroughly with a soft cloth.
4. Clean the glass surfaces with special glass cleaning agents.
5. Do not clean your oven with steam cleaners.
6. Before opening the upper lid of the oven, clean spilled liquid off the lid. Also, before closing the lid, ensure that the cooker table is cooled enough.
7. Never use inflammable agents like acid, thinner and gasoline when cleaning your oven.
8. Do not wash any part of your oven in dishwasher.
9. In order to clean the front glass lid of the oven; remove the fixing screws fixing the handle by means of a screwdriver and remove the oven door. Than clean and rinse it thoroughly. After drying, place the oven glass properly and re-install the handle.

Installation Of The Oven Door

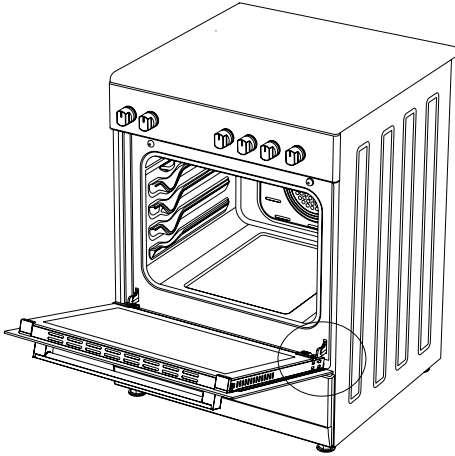

Figure 2

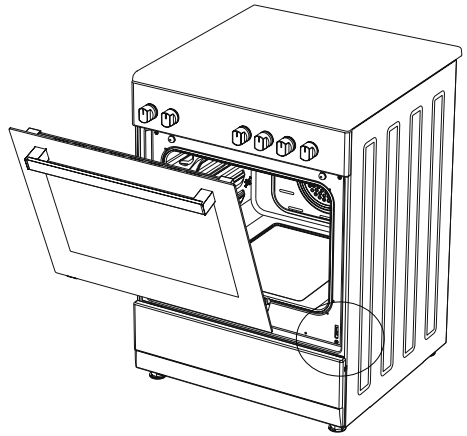

Figure 3

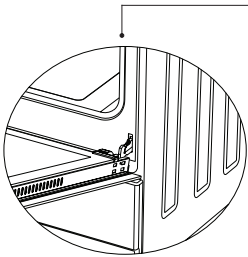

Figure 2.1

Completely open the oven door by pulling it to yourself. Afterwards, perform the unlocking process by pulling the hinge lock upwards with the help of a screw driver as shown in **figure 2.1**.

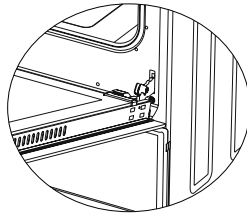

Figure 2.2

Bring the hinge lock to the widest angle as shown in **figure 2.2**. Bring both hinges connecting the oven door to the oven to the same position.

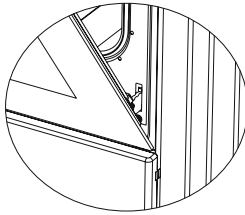

Figure 3.1

Afterwards, close the oven door as to lean on the hinge lock as shown in **figure 3.1**.

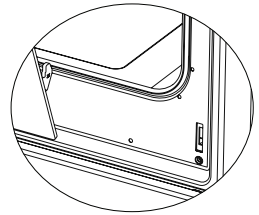

Figure 3.2

To remove the oven door, pull it upwards by holding it with both hands when close to the closed position as shown in **figure 3.2**.

In order to re-place the oven door, perform the abovementioned steps in reverse.

Cleaning And Maintenance Of The Oven's Front Door Glass

Remove the profile by pressing the plastic latches on both left and right sides as shown in figure 4 and pulling the profile towards yourself as shown in figure 5. Then remove the inner-glass as shown in figure 6. If required, middle glass can be removed in the same way. After cleaning and maintenance are done, remount the glasses and the profile in reverse order. Make sure the profile is properly seated in its place.

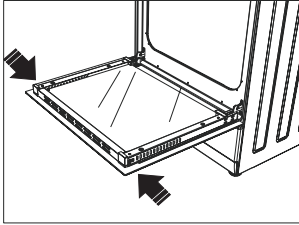

Figure 4

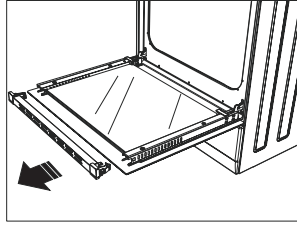

Figure 5

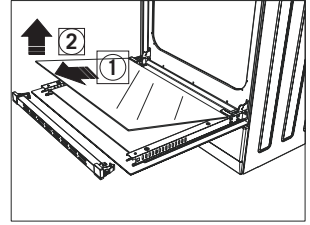

Figure 6

Catalytic Walls *

Catalytic walls are located on the left and the right side of cavity under the guides. Catalytic walls banish the bad smell and obtain the best performance from the cooker. Catalytic walls also absorb oil residue and clean your oven while it's operating.

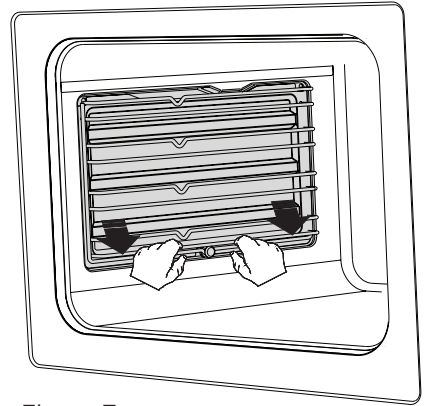
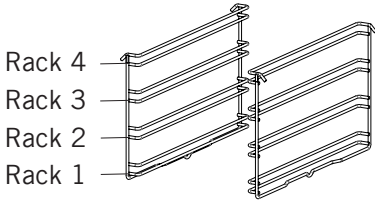

Figure 7

Removing the catalytic walls

In order to remove the catalytic walls; the guides must be pulled out. As soon as the guides are pulled out, the catalytic walls will be released automatically. The catalytic walls must be changed after 2-3 years.

Rack Positions



It is important to place the wire grill into the oven properly. Do not allow wire rack to touch rear wall of the oven. Rack positions are shown in the next figure. You may place a deep tray or a standard tray in the lower and upper wire racks.

Installing and removing wire racks

To remove wire racks, press the clips shown with arrows in the figure, first remove the lower, and then the upper side from installation location. To install wire racks; reverse the procedure for removing wire rack.

Changing The Oven Lamp

WARNING: To avoid electric shock, ensure that the appliance circuit is open before changing the lamp. (having circuit open means power is off) First disconnect the power of appliance and ensure that appliance is cold.

Remove the glass protection by turning as indicated in the figure on the left side. If you have difficulty in turning, then using plastic gloves will help you in turning.

Then remove the lamp by turning, install the new lamp with same specifications.

Reinstall glass protection, plug the power cable of appliance into electrical socket and complete replacement. Now you can use your oven.

Type G9 Lamp

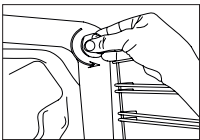

220-240 V, AC
15-25 W

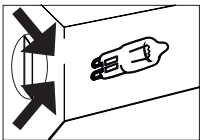

Figure 8

Type E14 Lamp



220-240 V, AC
15 W

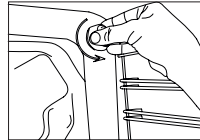

Figure 9

Using The Grill Deflector Sheet *

1. A safety panel is designed to protect control panel and the buttons when the oven is in grill mode. (figure 10)

2. Please use this safety panel in order to avoid the heat to damage control panel and the buttons when the oven is grill mode.

WARNING: Accessible parts may be hot when the grill in use. Young children should be kept away.

3. Place the safety panel under control panel by opening the oven front cover glass. (figure 11)

4. And then secure the safety panel in between oven and front cover by gently closing the cover. (figure 12)

5. It is important for cooking to keep the cover open in specified distance when cooking in grill mode.

6. Safety panel will provide an ideal cooking circumstance while protecting control panel and buttons.

WARNING: If the cooker has the “**closed grill functioned**” option with thermostat, you can keep the oven door closed during operation; in this case the grill deflector sheet will be unnecessary.

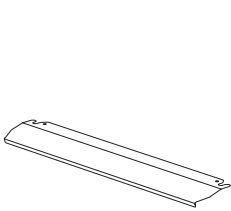

Figure 10

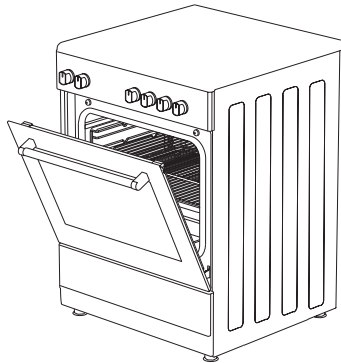

Figure 11

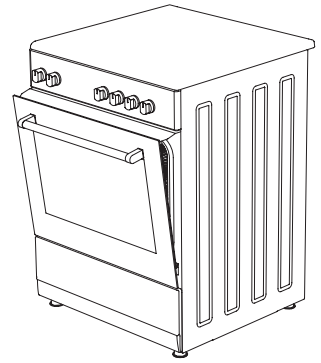

Figure 12

TROUBLESHOOTING

You may solve the problems you may encounter with your product by checking the following points before calling the technical service.

Check Points

In case you experience a problem about the oven, first check the table below and try out the suggestions.

Problem	Possible Cause	What to Do
Oven does not operate.	Power supply not available.	Check for power supply.
Turns off during cooking.	Too long continuous operation.	Let the oven cool down after long cooking cycles.
Oven door is not opening properly.	Food residues jammed between the door and internal cavity.	Clean the oven well and try to re-open the door.
Electric shock when touching the oven.	No proper grounding.	Make sure power supply is grounded properly.
	Ungrounded wall socket is used.	
Water dripping.	Water or steam may generate under certain conditions depending on the food being cooked. This is not a fault of the appliance.	Let the oven cool down and then wipe dry with a dishcloth.
Steam coming out from a crack on oven door.		
Water remaining inside the oven.		
Smoke coming out during operation.	When operating the oven for the first time	Smoke comes out from the heaters. This is not a fault. After 2-3 cycles, there will be no more smoke.
	Food on heater.	Let the oven to cool down and clean food residues from the heater.

Problem	Possible Cause	What to Do
When operating the oven burnt or plastic odour coming out.	Plastic or other not heat resistant accessories are being used inside the oven.	At high temperatures, use suitable glassware accessories.
Oven does not heat.	Oven door is open.	Close the door and restart.
	Oven controls not correctly adjusted.	Read the section regarding operation of the oven and reset the oven.
	Fuse tripped or circuit breaker turned off.	Replace the fuse or reset the circuit breaker. If this is repeating frequently, call an electrician.
Oven does not cook well.	Oven door is opened frequently during cooking.	Do not open oven door frequently, if the food you are cooking does not require turning. If you open the door frequently internal temperature drops and therefore cooking result will be influenced.
Internal light is dim or does not operate.	Foreign object covering the lamp during cooking.	Clean internal surface of the oven and check again.
	Lamp might be failed.	Replace with a lamp with same specifications.



HANDLING RULES

1. Do not use the door and/or handle to carry or move the appliance.
2. Carry out the movement and transportation in the original packaging.
3. Pay maximum attention to the appliance while loading/unloading and handling.
4. Make sure that the packaging is securely closed during handling and transportation.
5. Protect from external factors (such as humidity, water, etc.) that may damage the packaging.
6. Be careful not to damage the appliance due to bumps, crashes, drops, etc. while handling and transporting and not to break or deform it during operation.

RECOMMENDATIONS FOR ENERGY SAVING

Following details will help you use your product ecologically and economically.

1. Use dark coloured and enamel containers that conduct the heat better in the oven.
2. As you cook your food, if the recipe or the user manual indicates that pre-heating is required, pre-heat the oven.
3. Do not open the oven door frequently while cooking.
4. Try not to cook multiple dishes simultaneously in the oven. You may cook at the same time by placing two cookers on the wire rack.
5. Cook multiple dishes successively. The oven will not lose heat.
6. Turn off the oven a few minutes before the expiration time of cooking. In this case, do not open the oven door.
7. Defrost the frozen food before cooking.

ENVIRONMENTALLY-FRIENDLY DISPOSAL

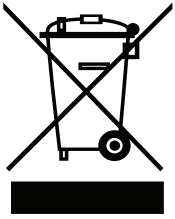

Dispose of packaging in an environmentally-friendly manner.

This appliance is labelled in accordance with European Directive 2012/19/EU concerning used electrical and electronic appliances (waste electrical and electronic equipment - WEEE). The guideline determines the framework for the return and recycling of used appliances as applicable throughout to the EU.

PACKAGE INFORMATION

Packaging materials of the product are manufactured from recyclable materials in accordance with our National Environment Regulations. Do not dispose of the packaging materials together with the domestic or other wastes. Take them to the packaging material collection points designated by the local authorities.